

THIS DRAWING IS UNPUBLISHED. RELEASED FOR PUBLICATION
 © COPYRIGHT - By - ALL RIGHTS RESERVED.

| LOC | DIST | REVISIONS | | | |
|-----|------|-------------|---------------------------|---------|-------|
| P | LTR | DESCRIPTION | DATE | DWN | APVD |
| AF | 50 | Y | REVISED PER ECR-13-004343 | 30JUL13 | KH KR |

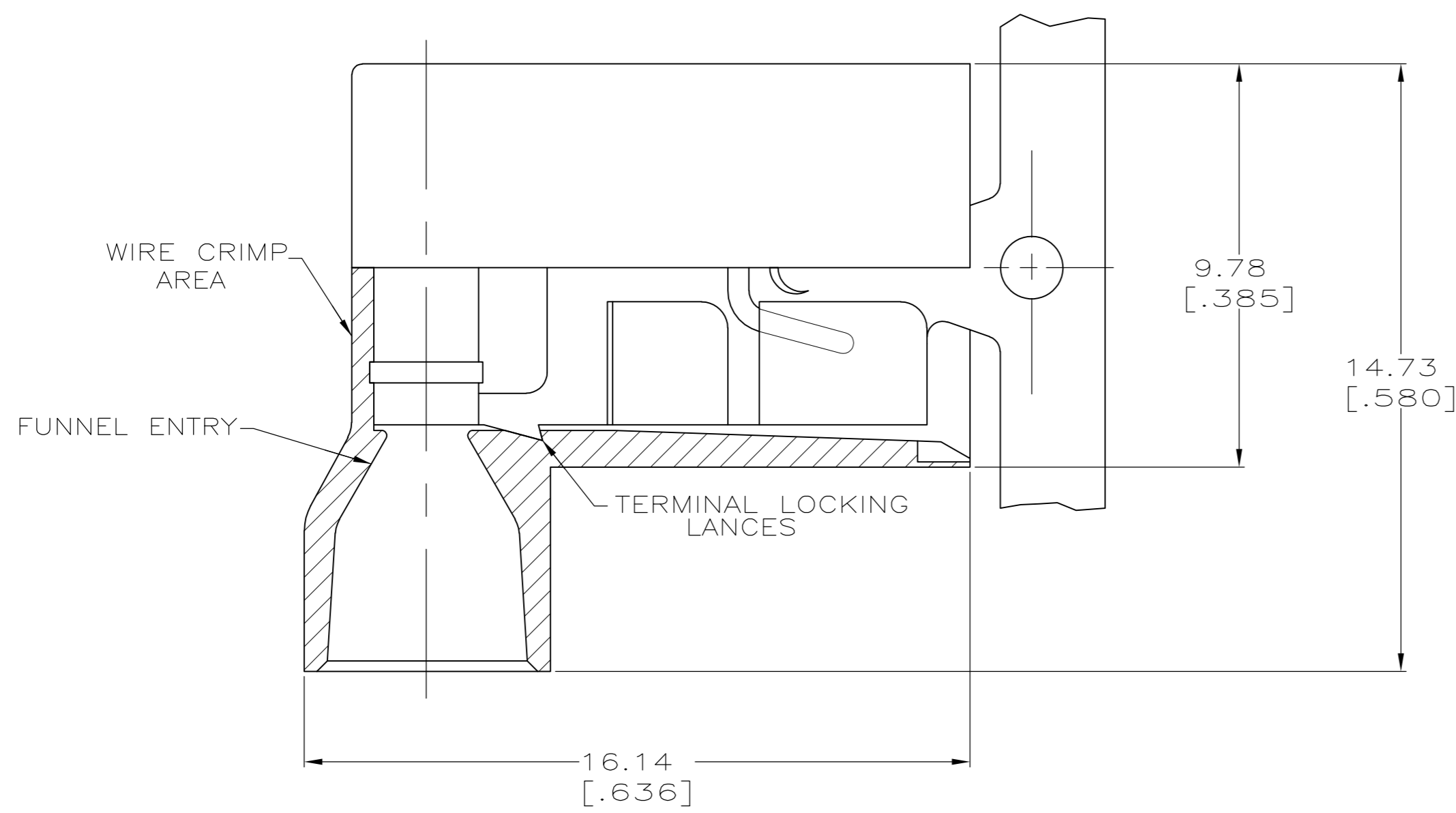

- 1 FITS 0.81±0.025 X 6.35 [.032±.001 X .250] TAB
- 2 WIRE SIZE: 0.3-0.9mm² [22-18 AWG], STRANDED ONLY. STRIP LENGTH 7.94 [.312]
- 3 INSULATION SIZE: 4.19 [.165] MAX DIA.
- 4 CONTINUOUS STRIP.

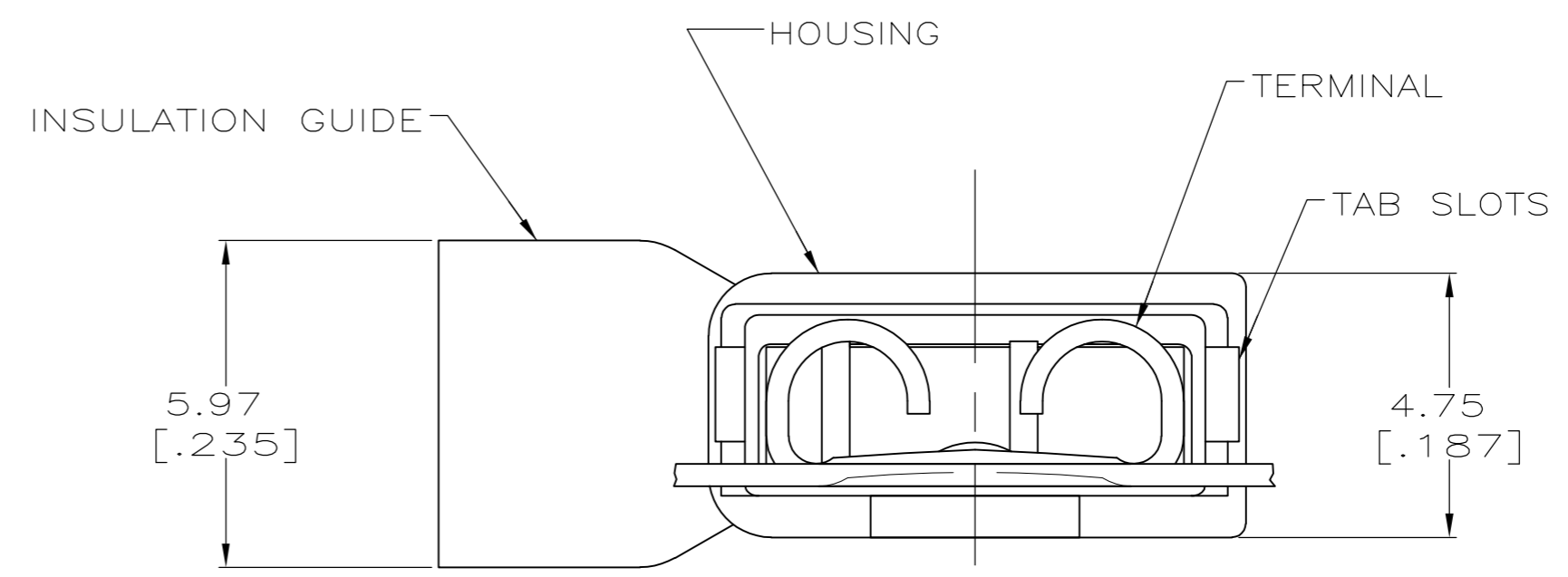
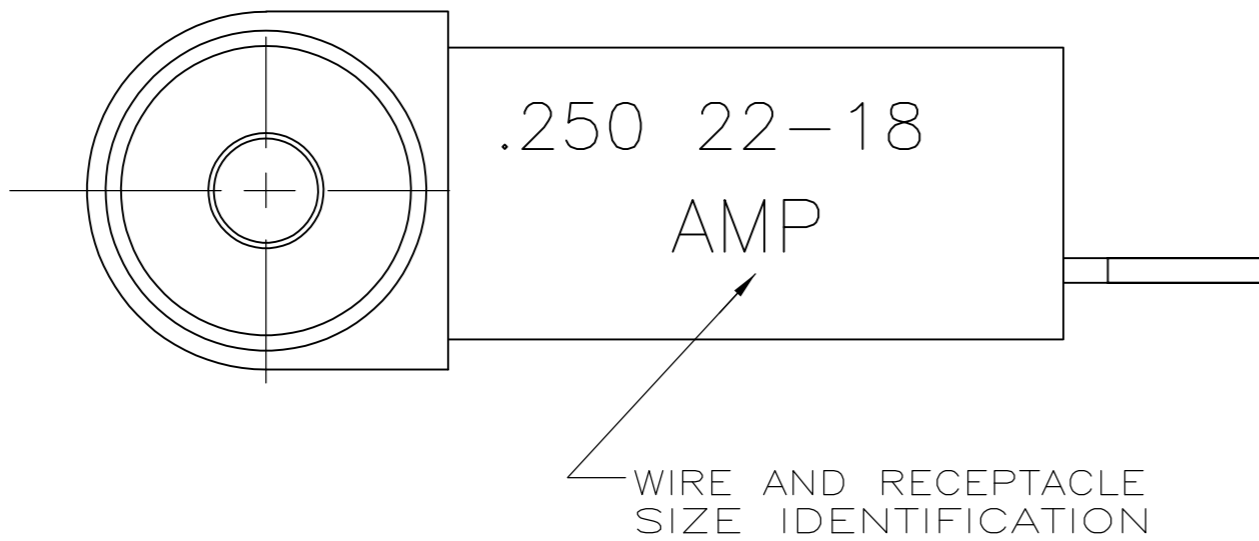

| | | | | | |
|-----------|----------------|-----------------|----------|--------|------------|
| BULK | TYPE 6/6 NYLON | RED TRANSLUCENT | BRASS | TIN | 5-520128-2 |
| STANDARD | | | | | 2-520128-2 |
| PACKAGING | MATERIAL | COLOR | MATERIAL | FINISH | PART NO |
| | HOUSING | | TERMINAL | | |

| | | | | | |
|---|------------------|---------------------------|--|-----------------|---------------------|
| THIS DRAWING IS A CONTROLLED DOCUMENT. | | DWN P FORTNEY 10/19/89 | RECEPTACLE ASSEMBLY, ULTRA-FAST FLAG, 6.35 [.250] SERIES | | |
| DIMENSIONS: MM [INCHES] | | CHK JR RUTH 10/19/89 | | | |
| TOLERANCES UNLESS OTHERWISE SPECIFIED: | | APVD D BRATINA 10/19/89 | | | |
| 0 PLC ± - 1 PLC ± - 2 PLC ± - 3 PLC ± 0.38 [.015] 4 PLC ± - ANGLES ± - | | PRODUCT SPEC 108-2043 | | | |
| MATERIAL SEE TABLE | FINISH SEE TABLE | APPLICATION SPEC 114-2123 | SIZE A2 | CAGE CODE 00779 | DRAWING NO C=520128 |
| CUSTOMER DRAWING | | | RESTRICTED TO - | SCALE 8:1 | SHEET 1 of 1 |